

KODAK Battery Storage

NL2.5 NL4.8 NL10.0 NL14.0



Installation Manual & User Guide



please read this manual carefully before
installing and operating the battery

Important Safety Instructions, Precautions

Please keep this manual for future reference

This manual contains all safety, installation and operation instructions for NL2.5/NL4.8/NL10.0/NL14.0 wall-mounted energy storage.

Please read all instructions and precautions in the manual carefully before installation and use. The company does not undertake the violation of general safety operation requirements or safety standards in the design, production and use of equipment any responsibility.

There is an unsafe voltage inside the energy storage battery. To avoid personal injury, users should not disassemble it by themselves. For maintenance, please contact professional maintenance personnel.

Precautions

- During the installation process, it is strictly forbidden to operate with power on, and connect the wires correctly during installation, and do not connect them in reverse.
- Please ensure that the parameters between related devices are compatible and matched.
- Please ensure that the installation environment of the equipment is well ventilated.
- When the equipment is running, do not block the vents or heat dissipation system to prevent fire caused by high temperature.
- Do not place the device in an environment of flammable, explosive gas or smoke, or high-salt spray environment, nor perform any operations in this environment.
- The load strength of the mounting surface should be greater than the load caused by the weight of the product.
- Please be properly grounded before use to ensure your safety.
- The annual temperature of the installation area should be between 0°C and 50°C.
- The relative humidity of the air should be less than 85%.

★ Warning

	<p>The scrapped battery cannot be put into the garbage can and must be professionally recycled.</p>
	<p>Do not place near open flame</p>
	<p>After the battery life is terminated, the battery can continue to be used after it recycled by the professional recycling organization and do not discard it at will.</p>
	<p>Do not cut or spear with sharp objects</p>
	<p>Do not extinguish with water in case of fire</p>
	<p>Do not use in corrosive environment</p>

Contents

1. Basic Information.....	4
1.1 Product overview and features.....	4
1.2 Basic parameters.....	5
1.3 Product introduction.....	7
2. Installation Instructions.....	8
2.1 Installation preparation.....	8
2.2 Engineering coordination.....	8
2.3 Equipment installation.....	9
2.4 Parallel connection.....	10
2.5 Electrical interface check.....	11
2.6 Electrical installation.....	11
2.7 Use, maintenance and troubleshooting.....	12
3. Operating mode.....	13
3.1 Charging voltage protection and charging current protection.....	13
3.2 Discharge voltage protection and discharge current protection.....	15
3.3 Ambient temperature alarm protection.....	17
3.4 Other Protection.....	17
3.5 Key description and buzzer action description.....	18
3.6 Working status of the indicator light.....	19
4. Communication Description.....	21
4.1 RS232.....	21
4.2 CAN.....	21
4.3 RS485.....	21
4.4 DIP switch setting.....	21
4.5 Communication interface definition as shown below.....	24
4.6 Electrical interface definition.....	25
4.7 Compatible to brand inverter.....	27
5. Storage and use environment requirements.....	28
6. Attachment table.....	28

1. Basic information

1.1 Product overview and features

Our products have been strictly tested and inspected before leaving the factory. If you find any abnormalities in the equipment, please contact the provider.

NL2.5/NL4.8/NL10.0/NL14.0 wall/Floor-mounted energy storage battery is a device used to store energy in a photovoltaic solar system.

Product features: This product is composed of high-quality lithium iron phosphate aluminum shell cells, high-efficiency BMS, and anti-static metal shell. The square aluminum shell cell has high stability and fast heat dissipation. The BMS effectively manages overcharge and over discharge, short circuit, and over temperature. The thickened metal shell has better protection performance.

Features of the system: NL2.5/NL4.8 can provide 100A continuous discharge and 100A charging capacity (recommended charging below 100A); NL10.0/NL14.0 can provide 200A continuous discharge and 200A charging capacity (recommended 100A) .It supports 6000 cycles of 80% DOD. A larger capacity battery pack can be formed by parallel connection to meet the long-term power supply needs of users. The closed line design is adopted to effectively prevent dust and mosquitoes from blocking the interface and increase the safety of use.

1.2 Basic parameters

ITEM	SPECIFICATIONS
Model	NL2.5
Nominal Voltage	25.6V
Capacity	100Ah
Energy Power	2.56Kwh
Equalized Charge Voltage	29.2V
Float Charge Voltage	28.4V
Max.Continuous Charging Current	100A (Recommended 50A)
Max.Continuous Discharging Current	100A
Max C Rating	1C
Model	NL4.8
Nominal Voltage	48V
Capacity	100Ah
Energy Power	4.8Kw.h
Equalized Charge Voltage	54.75V
Float Charge Voltage	53.25V
Max.Continuous Charging Current	100A (Recommended 50A)
Max.Continuous Discharging Current	100A
Max C Rating	1C

Model	NL10.0
Nominal Voltage	51.2V
Capacity	200Ah
Energy Power	10.24Kwh
Equalized Charge Voltage	58.4V
Float Charge Voltage	56.8V
Max.Continuous Charging Current	200A (Recommended 100A)
Max.Continuous Discharging Current	200A
Max C Rating	1C
Model	NL14.0
Nominal Voltage	51.2V
Capacity	280Ah
Energy Power	14.34Kwh
Equalized Charge Voltage	58.4V
Float Charge Voltage	56.8V
Max.Continuous Charging Current	200A (Recommended 100A)
Max.Continuous Discharging Current	200A
Max C Rating	1C

1.3 Product introduction

Model: NL 2.5 / NL 4.8

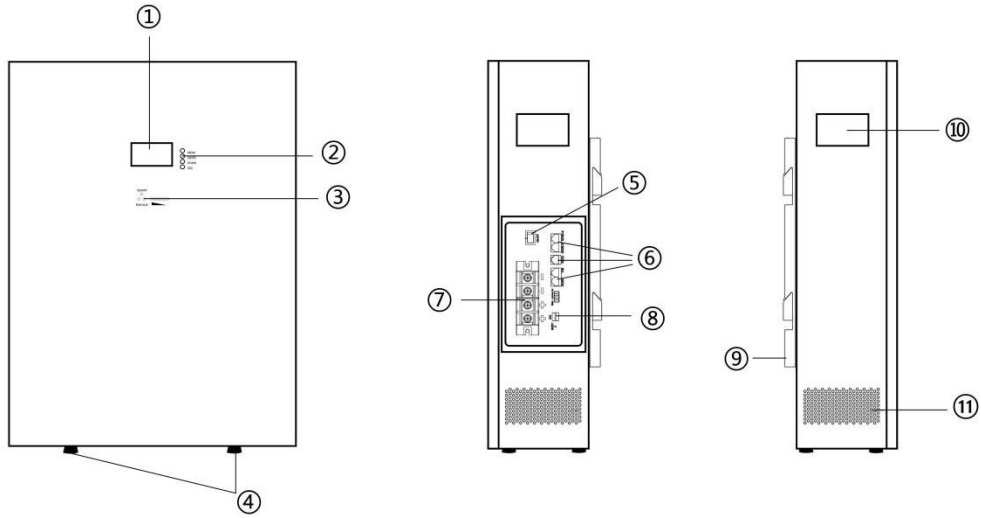

- ① LCD Screen
- ② Button
- ③ Indicator Light
- ④ Foothold
- ⑤ Power On/Off

- ⑥ Communication Interface
- ⑦ Positive/Negative Terminal
- ⑧ ADS
- ⑨ Bracket
- ⑩ Handle
- ⑪ Heat Sink Hole

Model: NL 10.0 / NL 14.0

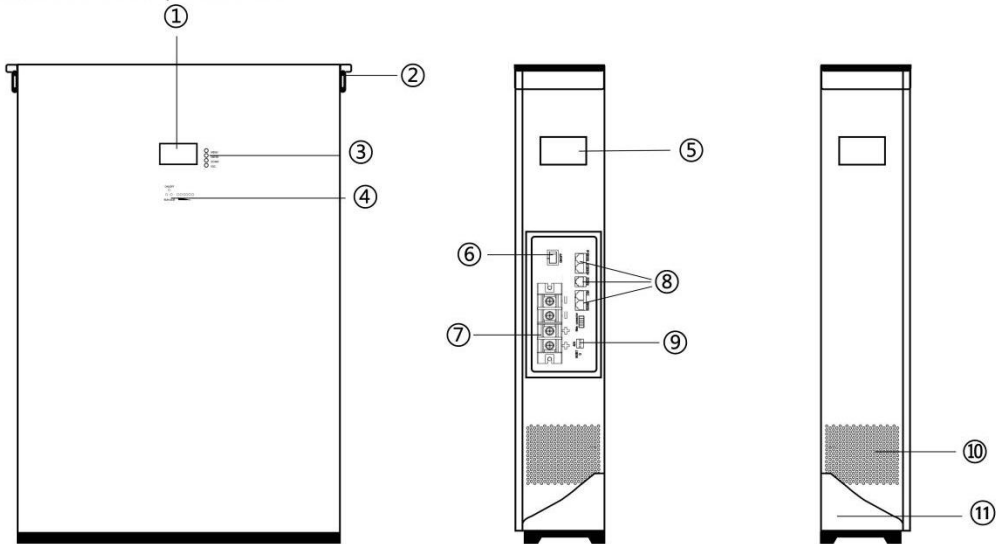

- ① LCD Screen
- ② Installation ears
- ③ Button
- ④ Indicator Light
- ⑤ Handle

- ⑥ Power On/Off
- ⑦ Positive/Negative Terminal
- ⑧ Communication Interface
- ⑨ ADS
- ⑩ Heat Sink Hole
- ⑪ Base

2. Installation instructions

2.1 Installation preparation

1. Safety Requirements: This system should only be installed by personnel who have received training in power systems and have sufficient knowledge of power systems. During installation, the safety regulations described below and local safety regulations should always be followed.
2. Make sure that all devices are powered off before operating, and use devices or accessories that match the battery parameters.
3. The wiring of power distribution cables should be reasonable and have protective measures to avoid contact with these cables when operating power equipment.
4. Wear appropriate protective measures, such as: goggles, gloves, installation clothing, etc.
5. Need to prepare installation tools:

Drill	Hammer	Wrench	Screw	Wire strippers
Insulating tape	Electric pencil	Multi meter	Pliers	Measuring ruler

2.2 Engineering coordination

Attention should be paid to the following items before construction.

- Power line specification: The power line specification shall meet the requirements of maximum discharge current for each product.
- Mounting space and bearing capacity: Make sure that the batteries has enough room to install, and that the batteries rack and bracket have enough load capacity.
- Make sure the power line and ground wire are reasonable. Not easy to short-circuit water and corrosion

2.3 Equipment installation

NL2.5/NL4.8 Wall mounted

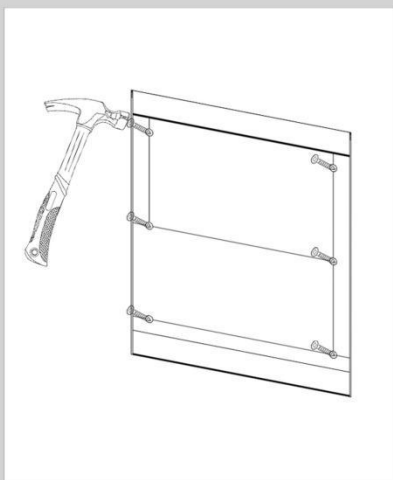

1. Align the bracket with the hole, place the expansion screw, and lock the expansion screw

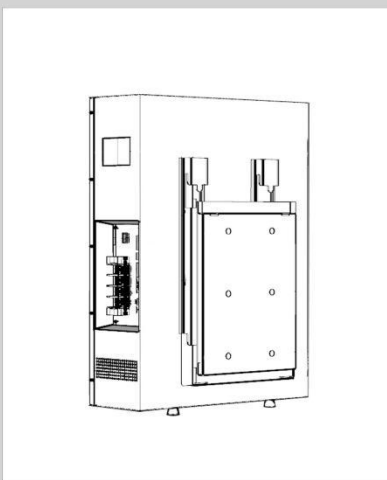

2. Align the clasp and hang the battery on the mounted bracket

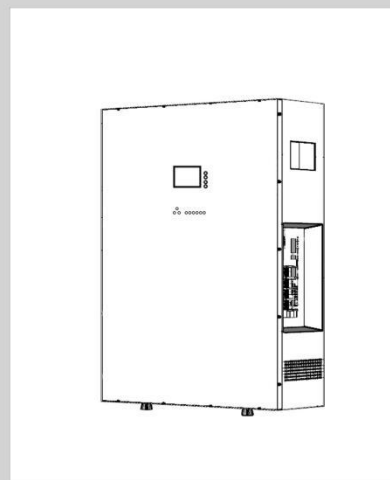

3. Installation complete

NL10.0 /NL14.0 Floor mounted

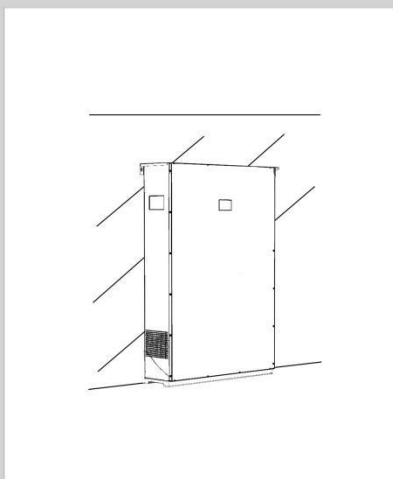

1. install the ears on battery and place the battery onto the battery base and attach the battery system to the wall.

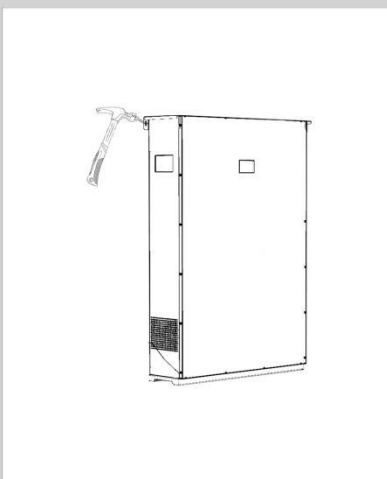

2. Place the expansion screws in line with the ear holes and tighten the expansion screws

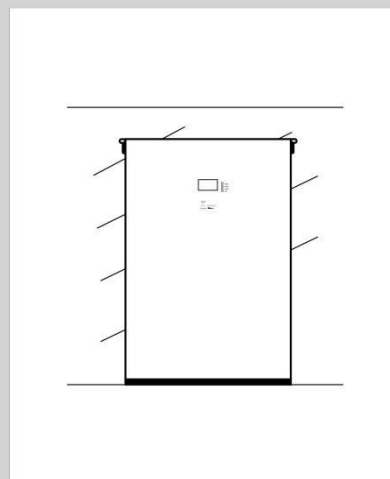

3. Installation complete

Step1	Installation preparation	Confirm that the ON/OFF switch is off.
Step3	Electrical Installation	1. Batteries parallel cable installation
		2. Batteries positive cable installation
		3. Batteries negative cable installation
Step4	Batteries System self-test	1. Press the ON/OFF switch to the "ON" state
		2. BMS system power on activation
		3. Check the system output voltage
		4. Shut down the system
Step5	Connecting inverter	1. Connect positive & negative cable to Inverter
		2. Connect RS485 cable to the inverter

2.4 Parallel connection

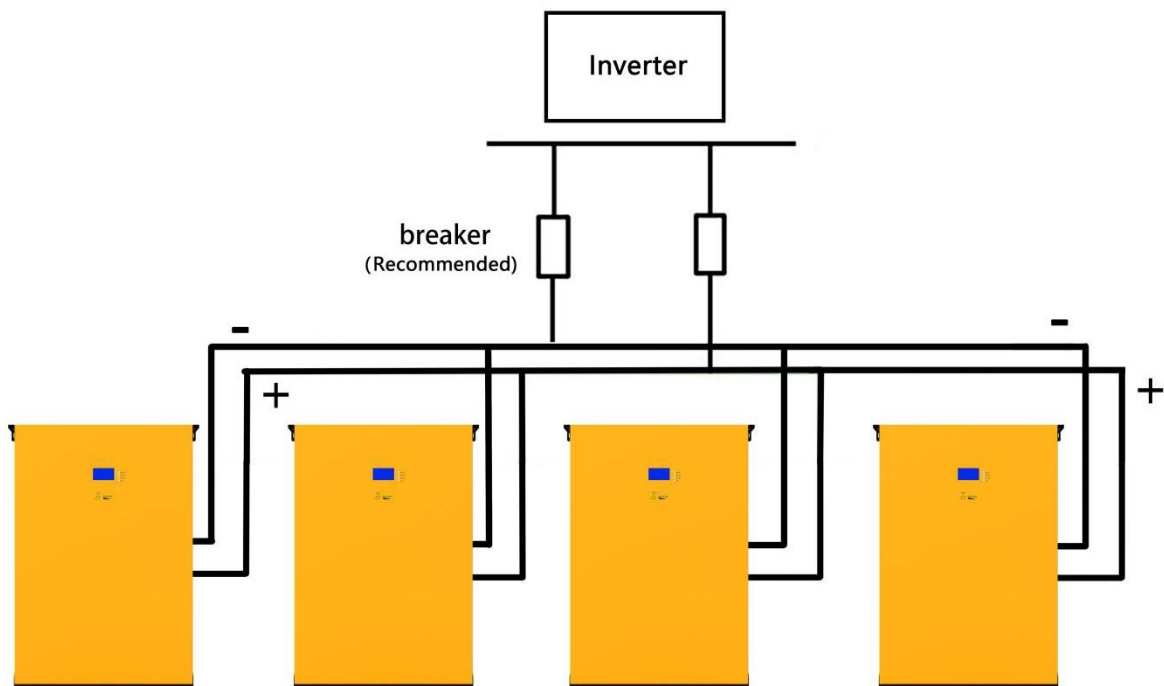

2.5 Electrical interface check

Devices that connected directly to the batteries can be user equipment, power supplies, and other power supplies.

- Please check if the user's PV power generation equipment, power supplier or other power supply equipment has a DC output interface, and the voltage meet the requirements of the inverter.
- And check the maximum discharge current capability of the DC power interface of the user's photovoltaic power generation equipment, power supply or other power supply equipment should be greater than the maximum charging current of the products.

2.6 Electrical installation

Before connecting the power cables, using multi meter to measure cable continuity, short circuit, confirm positive and negative, and accurately mark the cable labels.

Measuring methods:

- Cable availability: select the buzzer and use the probe to measure the ends of the same color cable. If the buzzer calls, it means the cable is available.
- Short circuit judgment: choose multi meter resistor file, probe the same end of positive and negative pole, if the resistor shows infinity, means that the cable is available.
- After visual testing of power line is connected well, the positive and negative poles of the batteries shall be connected respectively to the positive and negative poles of the opposite terminal.

2.7 Use, maintenance and troubleshooting

Batteries system usage and operation instructions

After completing the electrical installation, follow these steps to start the batteries system

1. Press the switch to ON position, The display screen and indicator will light up
2. After the indicator self-test, the RUN indicator will light and the SOC indicator will be on.



Note:

1. After pressing the power button, if the batteries status indicator on the front panel continues to be red, please refer to the "3.6 Alarm description and processing ".If the failure cannot be eliminated, please contact the dealer timely.
2. After confirming that the batteries output voltage and polarity are correct, turn on the inverter, close the circuit breaker.
3. Check if the indicator of the inverter and batteries connection (communication indicator and batteries access status indicator) is normal. if it is normal, successfully complete the connection between the batteries and the inverter. If the indicator light is abnormal, please refer to the inverter manual for the cause or contact the dealer.

3. Operating mode

3.1 Charging voltage protection and charging current protection

NL2.5 25.6V/100AH

Overcharge protection	Overcharge warning voltage	28.4V
	Overcharge protection voltage	28.8V
	Overcharge protection delay	1.0S

Charging voltage protection

Charging over current protection	Charging over current warning current	100A
	Charging over current protection current	105A
	Charge over current protection delay	1.0S

Charging current protection

NL4.8 48V/100AH

Overcharge protection	Overcharge warning voltage	53.25V
	Overcharge protection voltage	54V
	Overcharge protection delay	1.0S

Charging voltage protection

Charging over current protection	Charging over current warning current	100A
	Charging over current protection current	105A
	Charge over current protection delay	1.0S

Charging current protection

51.2V/200AH NL10.0

51.2V/280AH NL14.0

overcharge protection	Overcharge warning voltage	56.8V
	Overcharge protection voltage	57.6V
	Overcharge protection delay	1.0S

Charging voltage protection

Charging over current protection	Charging over current warning current	205A
	Charging over current protection current	210A
	Charge over current protection delay	1.0S

Charging current protection

3.2 Discharge voltage protection and discharge current protection

NL2.5 25.6V/100AH

over-discharge protection	Over-discharge warning voltage	22.4V
	Over-discharge protection voltage	22V
	Over-discharge protection delay	1.0S

Discharge voltage protection

Discharge over current 1 protection	Discharge over current 1 alarm current	100A
	Discharge over current 1 protection current	105A
	Discharge over current 1 protection delay	5.0S
Discharge over current 2	Discharge over current 2 protection current	≥120A
	Discharge over current 2 protection delay	1500mS

Discharge current protection

NL4.8 48V/100AH

over-discharge protection	Over-discharge warning voltage	42V
	Over-discharge protection voltage	41.25 V
	Over-discharge protection delay	1.0S

Discharge voltage protection

Discharge over current 1 protection	Discharge over current 1 alarm current	100A
	Discharge over current 1 protection current	105A
	Discharge over current 1 protection delay	5.0S
Discharge over current 2	Discharge over current 2 protection current	≥120A
	Discharge over current 2 protection delay	1500mS

Discharge current protection

NL10.0 51.2V/200AH

NL14.0 51.2V/280AH

over-discharge protection	Over-discharge warning voltage	44.8V
	Over-discharge protection voltage	44V
	Over-discharge protection delay	1.0S

Discharge voltage protection

Discharge over current 1 protection	Discharge over current 1 alarm current	205A
	Discharge over current 1 protection current	210A
	Discharge over current 1 protection delay	5.0S
Discharge over current 2	Discharge over current 2 protection current	≥250A
	Discharge over current 2 protection delay	1500mS

Discharge current protect

3.3 Ambient temperature alarm protection

Ambient temperature warning	Ambient low temperature warning temperature	-15°C
	Ambient low temperature protection temperature	-20°C
	Ambient low temperature protection release temperature	-15°C
	Ambient high temperature warning temperature	65°C
	Ambient high temperature protection temperature	75°C
	Environmental high temperature protection contact temperature	65°C

3.4 Other Protection

Short Circuit Protection

When there is a short circuit situation, the short-circuit protection will be triggered and the protection will be released after the load is removed or there's a charging source connected.

Self- Shutdown

When there are no external loads and power supply and no external communication for over 24 hours, the device will dormant standby automatically.

3.5 Key description and buzzer action description

Key description

- When the BMS is in sleep state, press the button (3~6S) and release it, the protection board will be activated, and the LED indicators will light up sequentially for 0.5 seconds from "RUN".
- When the BMS is active, press the button (3~6S) and then release it, the protection board will be dormant, and the LED indicators will light up for 0.5 seconds from the lowest battery light.
- When the BMS is active, press the button (6~10S) and release it, the protection board will be reset, and all LED lights will light up simultaneously for 1.5 seconds.
- After the BMS is reset, it still retains the parameters and functions set by the host computer. If it is necessary to restore the initial parameters, it can be realized through the "restore default value" of the host computer. However, the relevant operating records and stored data remain unchanged (such as power, cycle times, protection records, etc.)

buzzer action description

- When there is a fault, it will beep 0.25S every 1S;
- During protection, it beeps for 0.25S every 2S (except for over voltage protection);
- When alarming, beep 0.25S every 3S (except for over voltage alarm);

The buzzer function can be enabled or disabled through the host computer, and the factory default is disabled.

3.6 Working status of the indicator light

LED working status indication

State	Normal / Alarm / Protection	ON/OFF	RUN	ALM	SOC Indication LEDs						Instructions	
		●	●	●	●	●	●	●	●	●		
Power Off	Sleep	OFF	OFF	OFF	OFF	OFF	OFF	OFF	OFF	OFF	OFF	All off
Standby	Normal	ON	Flash1	OFF	Indication by SOC						Standby	
	Alarm	ON	Flash1	Flash3							Cell low voltage	
Charge	Normal	ON	ON	OFF	Indication by SOC (The top SOC Led Flash 2)						Maximum power LED flash(flash 2),ALM does not flash for over-charge warning	
	Alarm	ON	ON	Flash3								
	Over Charge Protection	ON	ON	OFF	ON	ON	ON	ON	ON	ON	ON	If no mains supply, LED as standby
	Temperature. Over-current. Fault Protection	ON	OFF	ON	OFF	OFF	OFF	OFF	OFF	OFF	OFF	Close charge
Discharge	Normal	ON	Flash3	OFF	Indication by SOC							
	Alarm	ON	Flash3	Flash3								
	Under	ON	OFF	OFF	OFF	OFF	OFF	OFF	OFF	OFF	OFF	Close
	Temperature. Over-current. Short Circuit Fault Protection	ON	OFF	ON	OFF	OFF	OFF	OFF	OFF	OFF	OFF	Close discharge
Fault		OFF	OFF	ON	OFF	OFF	OFF	OFF	OFF	OFF	OFF	Close charge Close discharge

State		Charge						Discharge					
Capacity indicator light		L6	L5	L4	L3	L2	L1	L6	L5	L4	L3	L2	L1
		●	●	●	●	●	●	●	●	●	●	●	●
Electricity (%)	0 ~ 16.6%	OFF	OFF	OFF	OFF	OFF	flash2	OFF	OFF	OFF	OFF	OFF	ON
	16.6 ~ 33.2%	OFF	OFF	OFF	OFF	flash2	ON	OFF	OFF	OFF	OFF	ON	ON
	33.2 ~ 49.8%	OFF	OFF	OFF	flash 2	ON	ON	OFF	OFF	OFF	ON	ON	ON
	49.8 ~ 66.4%	OFF	OFF	flash2	ON	ON	ON	OFF	OFF	ON	ON	ON	ON
	66.4 ~ 83.0%	OFF	flash2	ON	ON	ON	ON	OFF	ON	ON	ON	ON	ON
	83.0~100%	flash2	ON	ON	ON	ON	ON	ON	ON	ON	ON	ON	ON
Running light ●		ON						flash(flash 3)					

Capacity Instructions

4. Communication Description

4.1 RS232

The BMS can communicate with the host computer through the RS232 interface, so that various information of the battery can be monitored through the host computer, including battery voltage, Current, temperature, status and battery production information, etc., the default baud rate is 9600bps.

4.2 CAN

CAN communication, the default communication rate is 500K

4.3 RS485

With dual RS485 interfaces, you can view the information of PACK, and the default baud rate is 9600bps. If you need to communicate with the monitoring device through RS485, the monitoring device acts as the host and polls the data according to the address

4.4 DIP switch setting

When the PACKS are used in parallel, different PACKS can be distinguished by setting the address through the DIP switch on the BMS. It is necessary to avoid setting the same address. For the definition of the BMS DIP switch, refer to the table below:

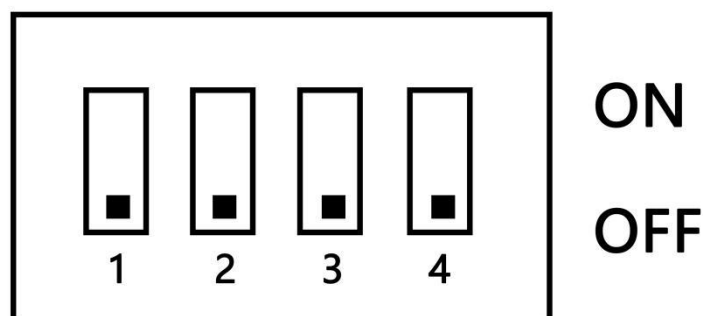

Address	Dial code switch position			
	#1	#2	#3	#4
0	OFF	OFF	OFF	OFF
1	ON	OFF	OFF	OFF
2	OFF	ON	OFF	OFF
3	ON	ON	OFF	OFF
4	OFF	OFF	ON	OFF
5	ON	OFF	ON	OFF
6	OFF	ON	ON	OFF
7	ON	ON	ON	OFF
8	OFF	OFF	OFF	ON
9	ON	OFF	OFF	ON
10	OFF	ON	OFF	ON
11	ON	ON	OFF	ON
12	OFF	OFF	ON	ON
13	ON	OFF	ON	ON
14	OFF	ON	ON	ON
15	ON	ON	ON	ON

Form 4.4

Demonstration of DIP switch for 4 unit batteries in parallel

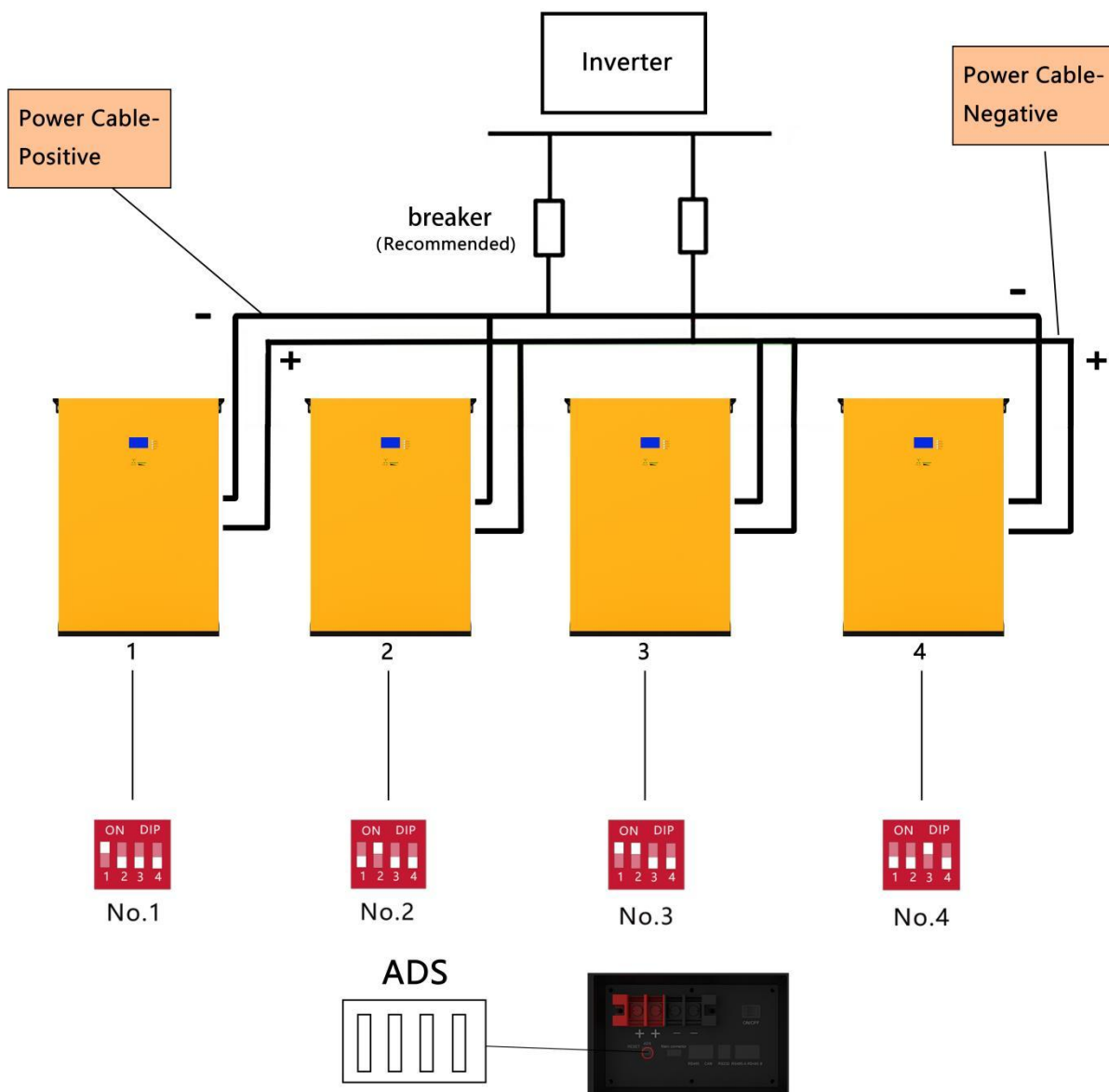

Please refer to form 4.4 for more equipment to be connected

4.5 Communication interface definition as shown below

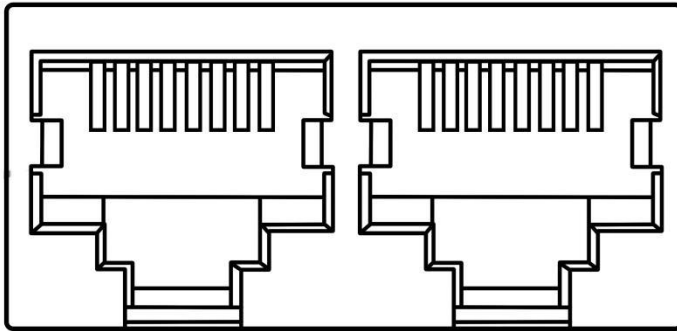

CAN and RS485 interface

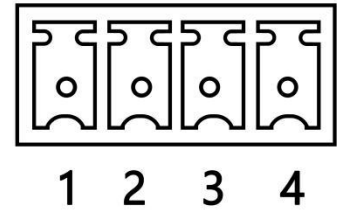

Dry contact

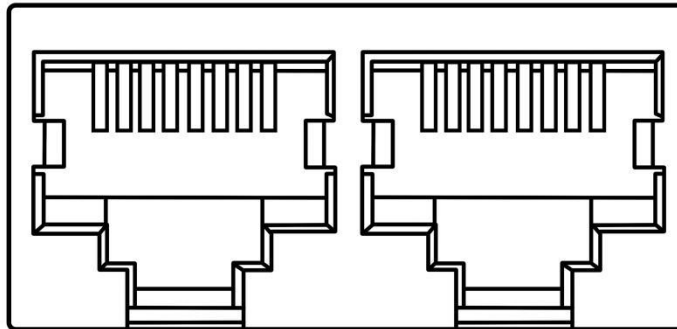

Parallel communication port

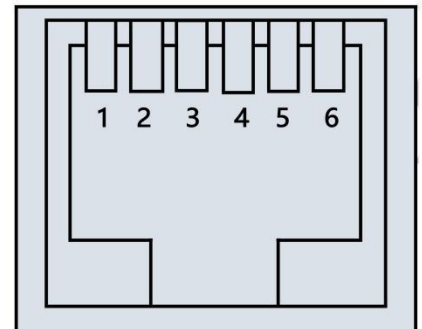

RS232 communication port

4.6 Electrical interface definition

RS232--Adopt 6P6C vertical RJ11 socket	
RJ11 pin	Definition description
2	NC
3	TX (vener)
4	RX (vener)
5	GND

CAN-- adopts 8P8C vertical RJ45 socket		RS485-- 8P8C vertical RJ45 socket	
RJ45 pin	specifies	RJ45 pin	specifies
1、 2、 3、 6、 8	NC	9、 16	RS485-B1
5	CANL	10、 15	RS485-A1
4	CANH	11、 14	GND
7	GND	12、 13	NC

CAN and RS485 interface

RS485-- 8P8C vertical RJ45 socket		RS485-- 8P8C vertical RJ45 socket	
RJ45 pin	specifies	RJ45 pin	specifies
1、 8	RS485-B	9、 16	RS485-B
2、 7	RS485-A	10、 15	RS485-A
3、 6	GND	11、 14	GND
4、 5	NC	12、 13	NC

Parallel communication port

Interface	Definition			
B+	The positive pole of the battery PACK is used to supply power to the BMS; the positive power P+ is directly connected to the positive pole of the battery			
B-	Battery PACK negative pole			
P-	The negative electrode of the battery PACK, that is, both the negative electrode for charging and the negative electrode for discharging (the same port for charging and discharging)			
	J2-1	NTC1	J4-1	NTC2
	J2-2	NTC	J4-2	NTC
	J2-3	CELL1-	J4-3	CELL5+
	J2-4	CELL1+	J4-4	CELL6+

	J2-5	CELL2+	J4-5	CELL7+
	J2-6	CELL3+	J4-6	CELL8+
	J2-7	CELL4+		
	J5-1	NTC3	J6-1	NTC4
	J5-2	NTC	J6-2	NTC
	J5-3	NC	J6-3	CELL13+
	J5-4	CELL9+	J6-4	CELL14+
	J5-5	CELL10+	J6-5	CELL15+
	J5-6	CELL11+	J6-6	CELL16+
	J5-7	CELL12+		



RJ11

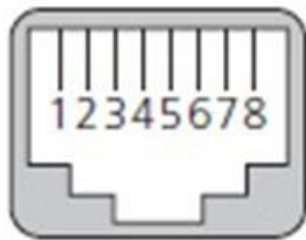

RJ45

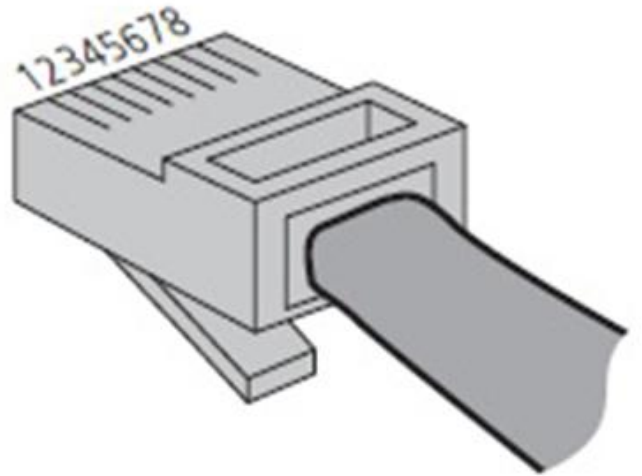

4.7 Compatible to brand inverter

NO	Brand of inverter
1	Deye
2	Pylontech
3	Growatt
4	Sofar
5	Luxpower
6	VOLTRONIC POWER
7	Sunsynk
8	Goodwe
9	Megarevo
10	Solis
11	Must
12	Srne
13	Schneider
14	Phocos
15	Victron energy
16	Sorotec
17	SMA
18	Aoguan
19	Invt
20	Sako
21	Solark
22	Afore
23	Mppsolar

5. Storage and use environment requirements

Working temperature: -20°C~+55°C

The charging temperature range: 0C~+55°C

Discharge temperature range: -20°C~+55°C

Storage temperature: -10°C~+35°C

Relative humidity: 5% ~ 85%RH

Altitude: no more than 4000m

During storage, recharge once every 6 months to 60%-80%DOD

Working environment: indoor installation, the site is protected from the sun, no wind, no conductive dust and corrosive gas

6. Attachment table

NO.	Item	Quantity	Note
1	KODAK Battery NL2.5	1	25.6V/100AH
	KODAK Battery NL4.8	1	48V/100AH
	KODAK Battery NL10.0	1	51.2V/200AH
	KODAK Battery NL14.0	1	51.2V/280AH
2	Positive cable	1	
3	Negative Cable	1	
4	Communication cable	1	
5	Expansion screw	6	
6	User manual	1	

Pay attention to check before unpacking

Loading and unloading should be carried out in accordance with the rules and regulations to prevent the sun and rain.

The total number of packages should be indicated on the shipping manifest accompanying each package and checked for completeness.

During the unpacking process, handle with care to protect the surface coating of the object.

When opening the package, the installer should read the technical documents, verify the list, and ensure that the items are complete and complete according to the configuration sheet and packing list. If the internal package is damaged, the shipper should be contacted in time

For further information visit www.bluemountainpv.com

©2023 Blue Mountain Energy LTD. The Kodak trademark, logo and trade dress are used under license from Kodak. Blue Mountain Energy Ltd., Crown House, 27 Old Gloucester Street, London WC1N 3AX.

Made in China.

